

Bottom Supported ^(BHS) Horizontal Sliding Unit



*Cabinet sold separately

BOTTOM SUPPORTED HORIZONTAL SLIDING UNITS

Customizable to fit various recessed settings, including any nook or cabinet

- Enhance visual communication and maximize writing space with our sliding units, which can be customized with any combination of writing and tackable surfaces.
- Enjoy effortlessly smooth motion with perfectly balanced weights on sliding panels, available in multiple track configurations.
- Designed and built for openings not exceeding 60" high.
- Writanium® Porcelain writing surfaces are projection-friendly and magnetically receptive, offering a flexible visual experience that will not ghost or stain.
- Writanium® Porcelain writing surfaces come with our "Forever Warranty."
- Writanium® Porcelain is SCS Indoor Advantage Gold Certified.

Suggested Specifications

Part 1: General

1.1 Section Includes

- A. Writanium® Porcelain Markerboards
- B. Writanium® Porcelain Chalkboards
- C. Colored Cork Tackboards

1.2 Related Sections

- A. Section 06100 – Wood or Steel Blocking
- B. Section 09000 – Gypsum Wall Board
- C. Section 09720 – Vinyl Wall Coverings
- D. Section 09900 – Paints and Coatings



1.3 References

- A. ASTM B221 – Standard Specification for Aluminum and Aluminum-Alloy Extruded Bars, Rods, Wire, Shapes, and Tubes.
- B. ASTM E84 – Test Method for Surface Burning and Characteristics of Building Materials.
- C. ASTM C540 – Gloss Test for Writanium® Porcelain (Porcelain Enamel Institute PEI-501).

1.4 Submittals

- A. Submit products and samples under provisions of Section 01300.
- B. Product Data: Provide technical data for products specified. Include Material Safety Data Sheets, when applicable.
- C. Shop Drawings: Provide shop drawings for each type of visual display board specified including section details indicating trim, face, core and backing materials, dimensions, joint locations and special anchor details.
- D. Color Samples: Submit set of color chips displaying manufacturer's full range of colors and finishes.
- E. Product Samples: Submit samples not less than twelve inches square and framed on two adjacent sides, to illustrate materials, finish, color, and configuration of each type of visual display board required.
- F. Care and Maintenance Data: Provide data on cleaning requirements, stain removal, and recommended maintenance precautions.

1.5 Delivery, Storage, and Handling

- A. Comply with manufacturer's instructions for handling and storage of Visual Display Boards.

1.6 Project Conditions

- A. Field measure prior to fabrication to ensure proper fit.
- B. General contractor to maintain proper climate before, during and after installation.

1.7 Warranty

- A. Submit manufacturer's "Forever Warranty", stating that under normal usage and maintenance, and when installed in accordance with manufacturer's instructions and recommendations, Writanium® Porcelain Markerboards and Chalkboards are guaranteed for the life of the building.
- B. Warranty shall cover replacement of defective Writanium® Porcelain Markerboards and Chalkboards due to discoloration, excessive fading of color, crazing, cracking or flaking. Warranty does not cover the cost of removal or reinstallation.

Part 2: Products

2.1 Manufacturers

- A. Provide visual display boards as manufactured by Platinum Visual Solutions, Corona, California.
Tel: (800)498-2990. Fax: (951)817-9900. Email: info@pvsusa.com. Website: www.pvsusa.com
- B. Substitutions: See Section 01600 – Product Requirements

2.2 Writanium® Porcelain Markerboards and Chalkboard Materials

- A. Steel Face Sheets: Writing surface will be Writanium® Porcelain 28 gauge steel face with porcelain enamel finish fused to the steel sheet using a continuous coil process.
 - 1. Writanium® Porcelain Markerboard and Chalkboard surface shall be fused at a temperature of 1450° and 1200° respectively.
 - 2. The gloss of the writing surface will not increase more than three units when subjected to wearability tests specified in testing procedures for 30 hours
- B. Core Material: 7/8" honeycomb
- C. Backing Material: .015" aluminum backing sheet
- D. Metal Trim and Accessories: 6063 aluminum alloy with a T5 temper
- E. Adhesive: As recommended by manufacturer for project conditions

2.3 Colored Cork Tackboard Materials

- A. Face Sheet: Colored cork surface will be 1/4" resilient homogenous tackable linoleum surface consisting of linseed oil, granulated cork, rosin binders and dry pigments calendared onto natural burlap backing. Color shall extend through thickness of material and be self-healing.
- B. Core Material: 5/8" honeycomb
- C. Backing Material: .015" aluminum backing sheet
- D. Metal Trim: 6063 aluminum alloy with T5 temper
- E. Adhesive: As recommended by manufacturer for project conditions

2.4 Bottom Supported Sliding Units

- A. Provide Bottom Supported Sliding Units with Writanium® Porcelain Markerboards, Chalkboards or Tackboards for project from manufacturer's BHS Series.
 - 1. Metal trim and accessories: BHS Series aluminum extrusions with clear satin anodized finish
 - a. Top Track CH200: One piece channel top track to accept nylon guide
 - b. Bottom Track BT640: One piece bottom track with integral roller guide
 - 2. Sliding Writanium® Porcelain Markerboard, Chalkboard and/or Tackboard Panels:
 - a. Frame CH250: Heavy duty channel frame with 1 1/4" face with no exposed fasteners on sides at corner joints
 - b. Adjustable Ball Bearing Rollers RG640: Two per panel up to 4' wide and three per panel up to 8' wide for smooth operation
 - c. Nylon Guides: Four per panel up to 4' wide and six per panel up to 8' wide
 - d. Finger Pulls IP230: One pair per sliding panel. Recessed into frame for flush fit (optional)
 - 3. Double Sided Sliding Writanium® Porcelain Markerboard or Chalkboard and Tackboard Panels:
 - a. Frame CH250: Heavy duty channel frame with 1 1/4" face with no exposed fasteners on sides at corner joints
 - b. Adjustable Ball Bearing Rollers RG640: Two per panel up to 4' wide and three per panel up to 8' wide for smooth operation
 - c. Nylon Guides: Four per panel up to 4' wide and six per panel up to 8' wide
 - d. SP200 Finger Pull: One pair per sliding panel. Recessed into frame for flush fit
 - 4. Size: As shown on drawings
 - 5. Color: As selected from manufacturer's standard colors

2.5 Fabrication

- A. Laminate facing sheet and backing sheet to core material under pressure, using manufacturer's recommended adhesive.
- B. Provide factory-assembled visual display boards, except where sizes demand partial field assembly.
- C. Assemble units in one piece without joints, wherever possible. Where required dimensions exceed maximum panel size available, provide two or more pieces of equal length, as indicated on approved shop drawings. Assemble to verify fit at factory, then disassemble for delivery and final assembly at project site.

Part 3: Execution

3.1 Examination

- A. Verify that substrates are properly prepared to receive visual display boards. Do not begin installation until unsatisfactory conditions have been corrected.

3.2 Installation

- A. Comply with manufacturer's installation instructions.
- B. Install visual display boards level and plumb, keeping perimeter trim aligned in accordance with manufacturer's recommendations.

3.3 Adjusting and Cleaning

- A. Verify that all accessories are installed as required for each unit.
- B. Upon completion of installation, clean surfaces and trim in accordance with manufacturer's recommendations, leaving all materials ready for use.

BHS: Specifications

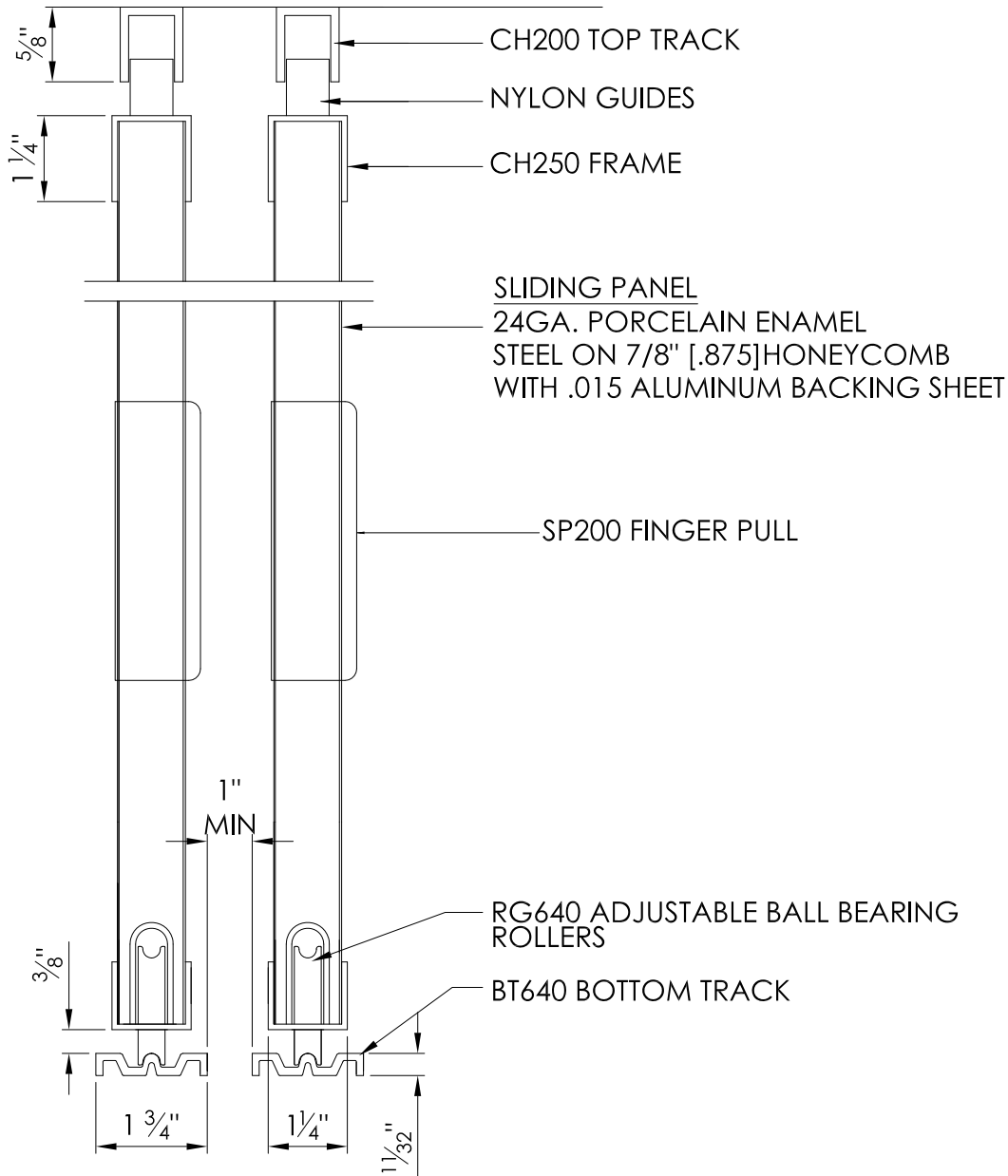

NOTE: 28GA. PORCELAIN ENAMEL STEEL USED FOR UNITS THAT EXCEED 5'-0" IN HEIGHT



Platinum
VISUAL SOLUTIONS

1451 E. Sixth Street, Corona, CA 92879
800.498.2990 | 951.817.2200 | FAX 951.817.9900
info@pvsusa.com | www.pvsusa.com